

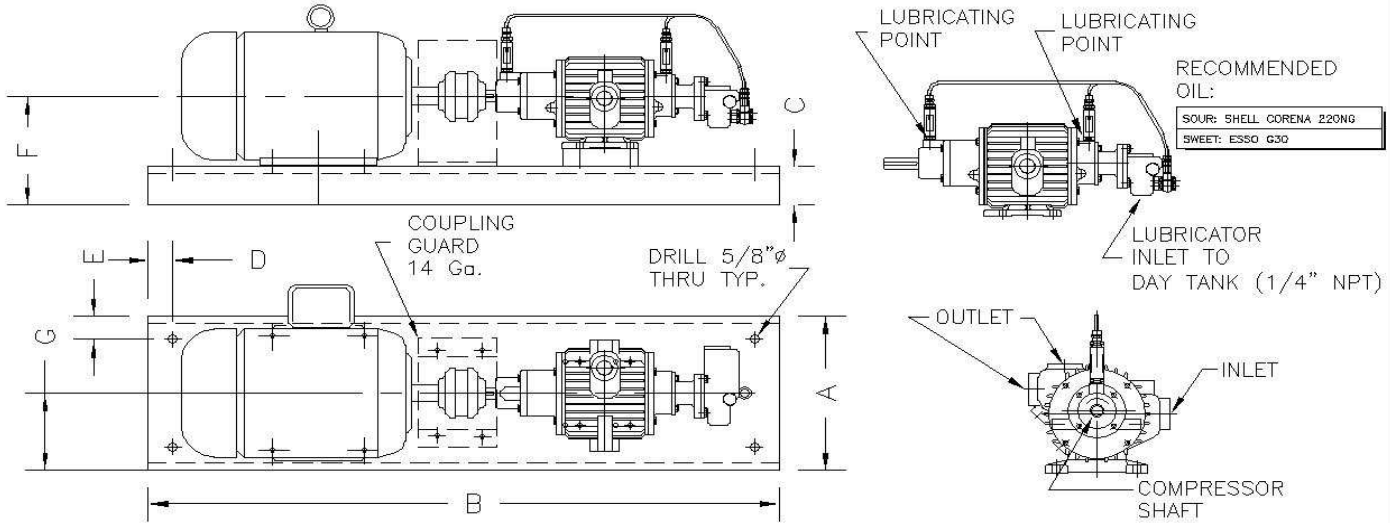

UTILE LGA 12 & 18 DISTANCE PIECE VACUUM COMPRESSOR

MANUFACTURED FOR SWEET/SOUR GAS SERVICE



RECOMMENDED OIL:
SOUR: SHELL CORENA 220NG
SWEET: ESSO G30

UTILE LGA 12 UNIT

MODEL	MOTOR SPECIFICATIONS	FRAME SIZE	COUPLING GUARD
LGA-12-1-12-1	1 HP / 1140 RPM / 115 - 230 V / 1 PH / 60 HZ XP	184	LGAGUARD-18
LGA-12-1-12-3	1 HP / 1140 RPM / 230 - 460 V / 3 PH / 60 HZ XP	145T	LGAGUARD-12
LGA-12-1.5-12-3	1.5 HP / 1140 RPM / 230 - 460 V / 3 PH / 60 HZ XP	182T	LGAGUARD-18
LGA-12-1.5-18-1	1.5 HP / 1725 RPM / 115 - 230 V / 1 PH / 60 HZ XP	184	LGAGUARD-18
LGA-12-1.5-18-3	1.5 HP / 1725 RPM / 230 - 460 V / 3 PH / 60 HZ XP	145T	LGAGUARD-12
LGA-12-2-18-1	2 HP / 1725 RPM / 115 - 230 V / 1 PH / 60 HZ XP	182T	LGAGUARD-18
LGA-12-2-18-3	2 HP / 1725 RPM / 230 - 460 V / 3 PH / 60 HZ XP	145T	LGAGUARD-12

UTILE LGA 18 UNIT

MODEL	MOTOR SPECIFICATIONS	FRAME SIZE	COUPLING GUARD
LGA-18-1.5-12-3	1.5 HP / 1140 RPM / 230 - 460 V / 3 PH / 60 HZ XP	182T	LGAGUARD-18
LGA-18-2-12-3	2 HP / 1140 RPM / 115 - 230 V / 3 PH / 60 HZ XP	184T	LGAGUARD-18
LGA-18-3-18-1	3 HP / 1725 RPM / 115 - 230 V / 1 PH / 60 HZ XP	215	GM-5X14 1.5 FT
LGA-18-3-18-3	3 HP / 1725 RPM / 230 - 460 V / 3 PH / 60 HZ XP	182T	LGAGUARD-18

LGA 12 DIMENSIONAL DATA

FRAME SIZE	A	B	C	D	E	F	G	BASE	SHIMS
145T	10"	38"	2 5/8"	1 1/2"	1 1/2"	6 1/4"	5"	LGA1038 (10" x 38")	N/A
182T & 184T	10"	38"	2 5/8"	1 1/2"	1 1/2"	7 1/4"	5"	LGA1038 (10" x 38")	LGASHIM-1 (1" x 1" x 4.5" L)

LGA 18 DIMENSIONAL DATA

FRAME SIZE	A	B	C	D	E	F	G	BASE	SHIMS
182T & 184T	10"	38"	2 5/8"	1 1/2"	1 1/2"	7 1/4"	5"	LGA1038 (10" x 38")	LGASHIM-1 (1" x 1" x 4.5" L)
215	10"	38"	2 5/8"	1 1/2"	1 1/2"	8"	5"	A1039 (10" x 39")	CHNL6-8.2 0.5 FT

EAGLE STANDARD PAINT SPECIFICATION

SURFACE PREPARATION	SSPC-SP3
PRIMER	ONE COAT OF SHOP PRIMER
TOP COAT(S)	UTILITY PIPING EAGLE STANDARD
	STRUCTURAL EAGLE STANDARD

EAGLE STANDARD PIPING SPECIFICATION

SPEC	1 1/2" & SMALLER	PIPE: A106 GR. N 3000#
		FITTINGS: A105 3000#
	TUBING	316SS 0.0035" WALL THICKNESS
	TUBING FITTING	CAD PLATED / 316 SS BACKER
	FERRULES	316SS